

Nsquare

Company Introduction

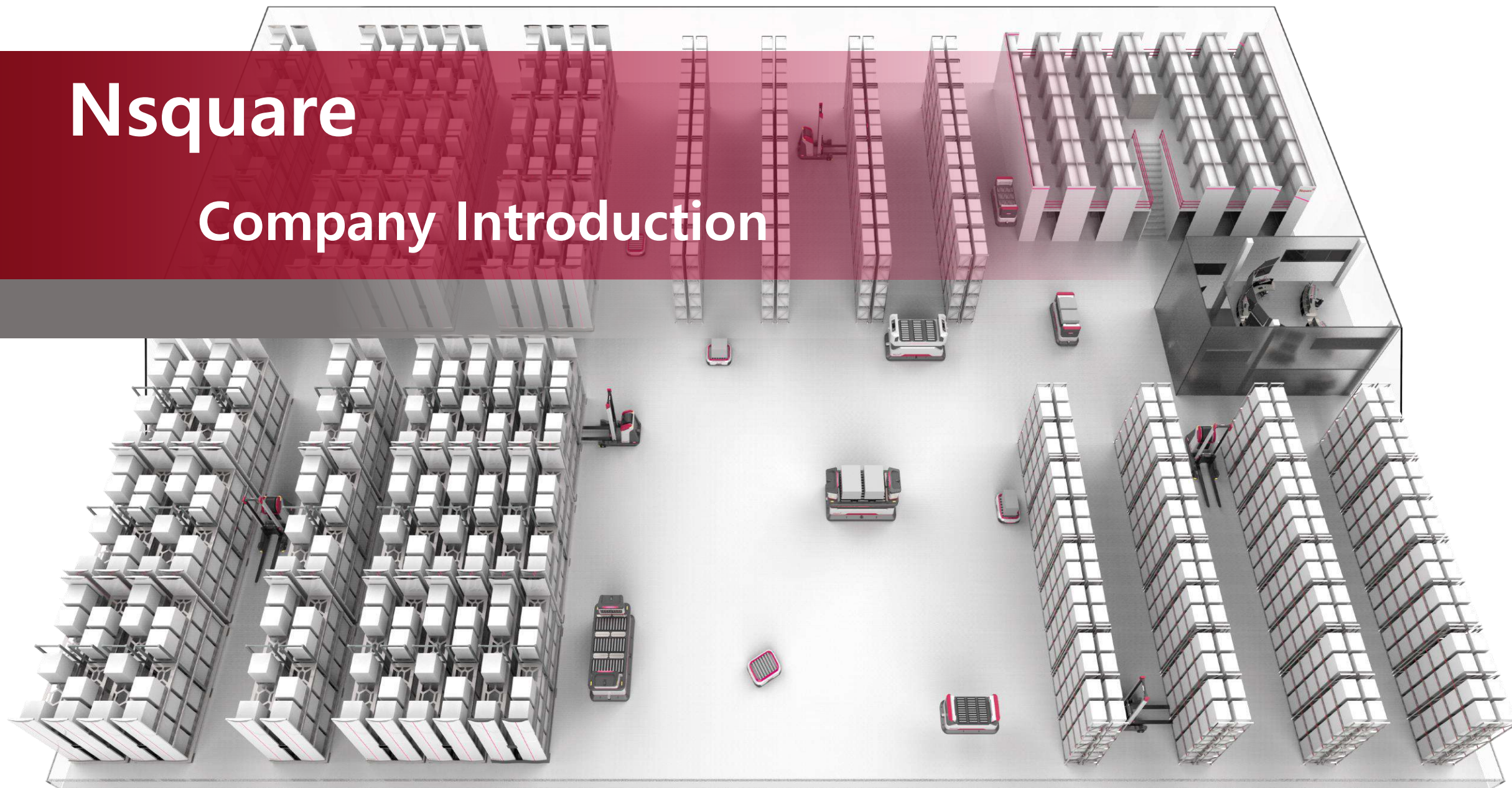

CONTENTS

01

COMPANY STATUS

- General Status of Company
- Major History
- Organization Chart

02

PRODUCT DESCRIPTION

- Logistics Robot (AGV, AMR)
- LiDAR Sensor

03

BUSINESS RESULT

04

R&D Result

01

Company
Status

Nsquare with Customer

Business Area : Logistics Robot(AGV, Automatic Guided Vehicle), Integrated Operating System of Robots, Part of Robot

Flagship Product : AGV of Semiconductor and Display Process, LiDAR Sensor, Driving Wheel, Motion Controller
, Integrated Operating Software of Robots(RCS)

Main Customer : Samsung Electronics / SK Hynix / LG Display

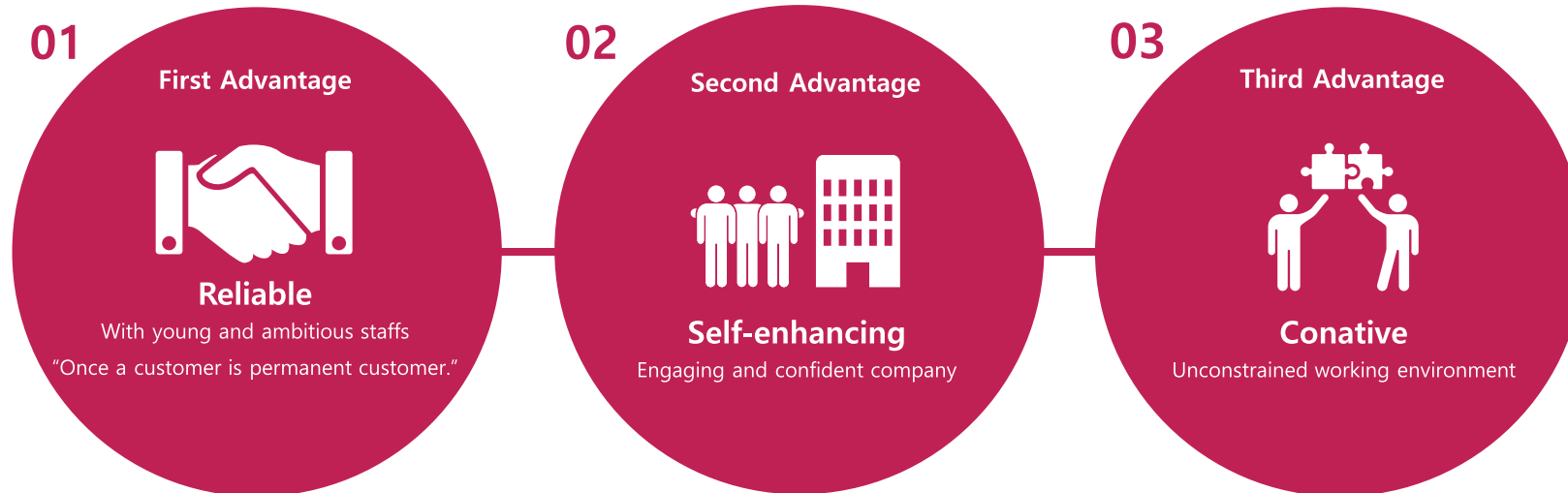

General Status of Company

| | |
|---------------------------|---|
| Company name | Nsquare Co., Ltd. |
| Establishment date | 03.23.2002 |
| CEO | Hyuk Yim |
| Employees | 20 |
| Business area | Logistical Robot(AGV, Automatic Guided Vehicle), Integrated Operating System of Robots, Part of Robot |
| Location | Head Office: 11-3, 4 SanDan 5 Gil , Jiksan-Eup, Seobuk-gu, Cheonan-si, Chungcheongnam-do, Korea Branch Office: C816, Indeokwon IT Valley, Poil-dong, Uiwang-si, Gyeonggi-do, Korea |
| Homepage | www.LGV.co.kr / www.nsquare.kr |
| Contact | Tel: 82-41-587-0300 E-mail: hswoo@lgv.co.kr |

Major History

2002 - 2006 Establishment (Logistics Automation System)

- Establishment of Nsquare Co., Ltd
- WAREHOUSE MANAGEMENT SYSTEM (WMS)
- EQUIPMENT CONTROL SYSTEM (ECS)
- Supply the systems to Samsung Electronics etc.

2007 - 2010 Development of AGV

- Initiation of development of AGV control system
- Supply of manual AGV (Samsung Corning Precision Materials, Samsung Electronics, Dongwoo, Koreno)
- Set up and test drive of AGV for Samsung Electronics

2011 - 2021 Market entry & growth

- Samsung Electronics AGV remodeling project
- Initiation of Supply of AGV to Samsung Electronics China Suzhou branch
- Selected for the government project of developing a high level, double-loading automatic forklift (Ministry of Land, for 3 years)
- Contract for supplying 64 AGVs with Samsung Electronics (Onyang, Giheung, Suzhou China)
- New supply to Samsung Electronics Gwangju, Gumi branches
- Main-biz / Commendation from Chungcheongnam-do Governor
- Selected for the government project of unmanned transporting robot (Ministry of Land, until 2018)
- Selected for the government project of LiDAR Sensor (the Small and Medium Business Administration, until 2016)
- Supply contract of new customer (LGDisplay Paju branch, LGDisplay China Guangzhou branch, SK Hynix etc.)
- Development of logistics transporting robot using SLAM method (Test operating at logistics center of CJ Korea Express)

Organization Chart

| Division | E-mail |
|------------------------|-------------------|
| Management support | ymhk@nsquare.kr |
| | |
| Logistics Robot | |
| Technical sales | hswoo@nsquare.kr |
| Hardware | wslee@nsquare.kr |
| Control Technology | mcshin@nsquare.kr |
| System Integration | symoon@nsquare.kr |
| Customer Service | bkpark@nsquare.kr |
| | |
| R&D Center | YH@nsquare.kr |
| | |
| Online Security | jwlee@nsquare.kr |

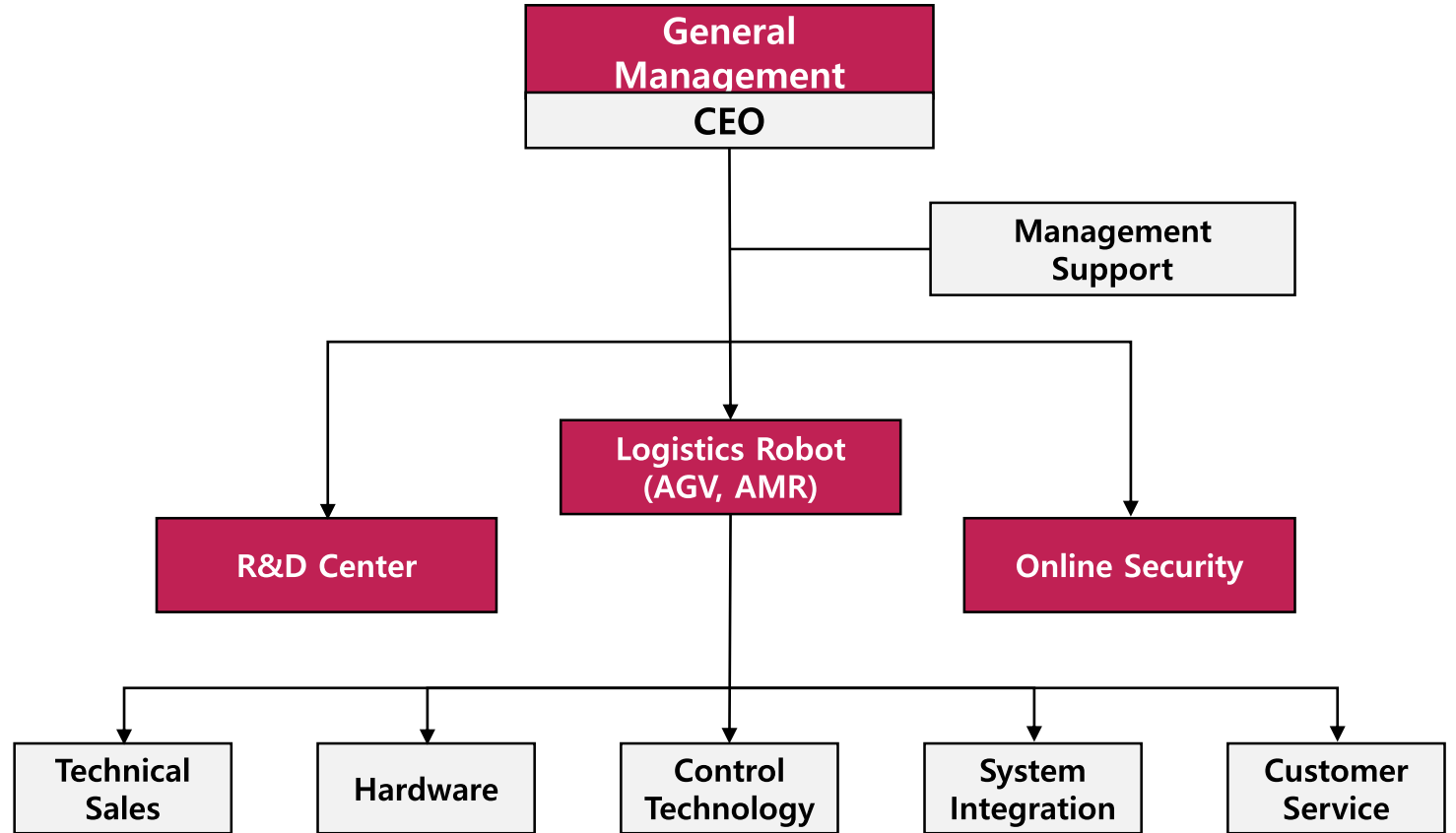

02

Product Description

Logistics Robot

-AGV (Automatic Guided Vehicle)

AGV is automated equipment(unmanned guided vehicle) designed to be used for distribution during supplies transportation / finished products transportation / test processes in various industrial



Features

- User oriented AGV
- Load type : Unit load, Forklift, Conveyor, co-bot and ETC.
- Position recognition : SLAM, Laser, Magnetic, Vision(camera), Line trace
- Convenient S/W
- Various support S/W

Logistics Robot

-AMR (Autonomous Mobile Robot)

Autonomous mobile robots(AMR) is one of the most innovative automation solutions on various industries and service.

AMR needless some form of external guidance, Such as permanent wires, laser reflectors or sensors embedded in the floor.

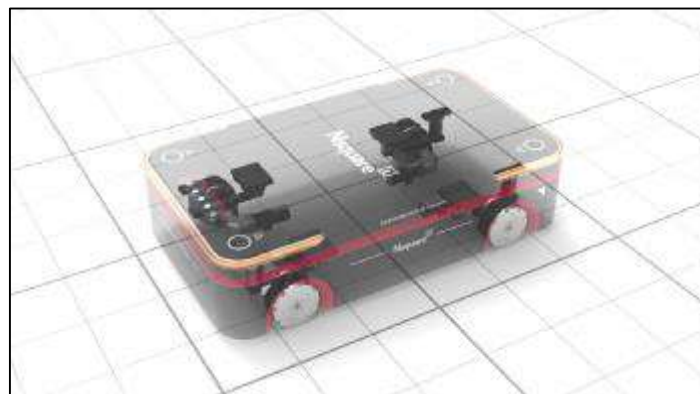
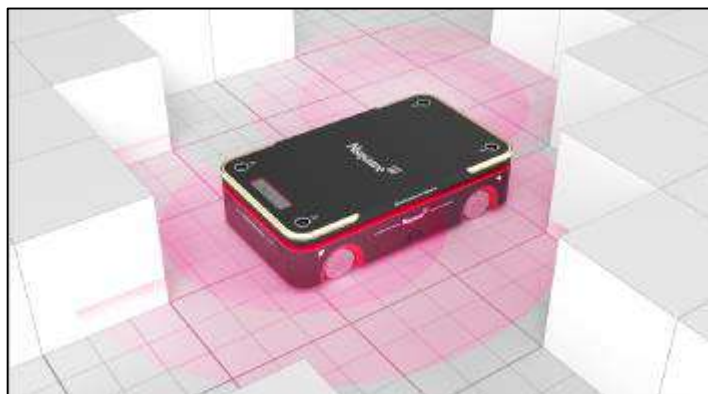

Features

- SLAM (Simultaneous localization and mapping).
- Omni-directional traveling.
- Various application.

Logistics Robot

-System Configuration Diagram

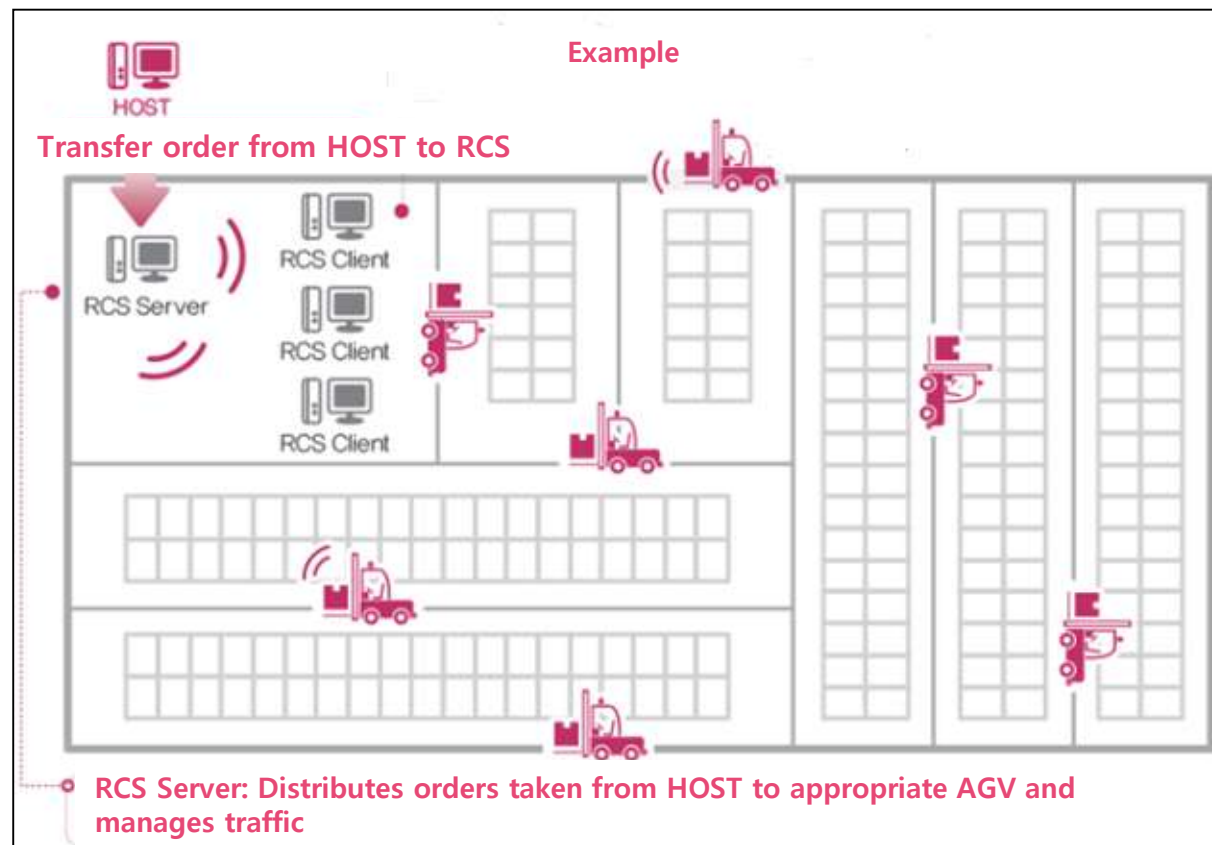
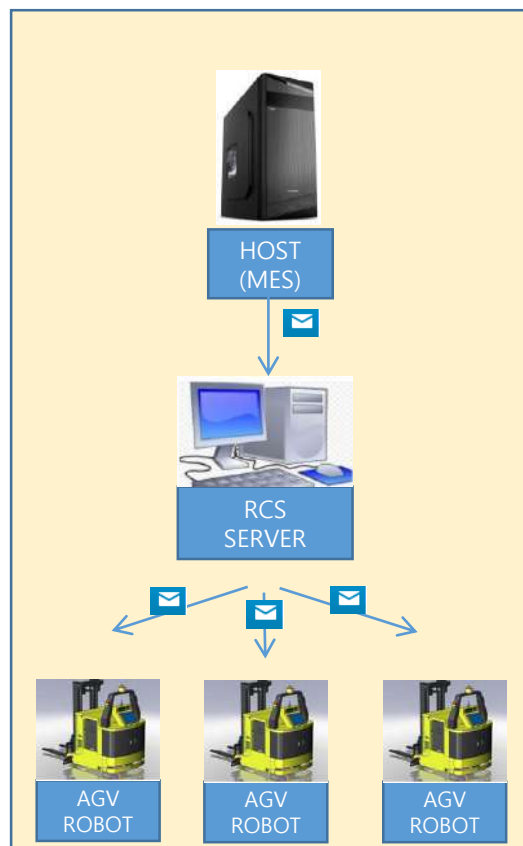

Logistics Robot

- Main Control Program

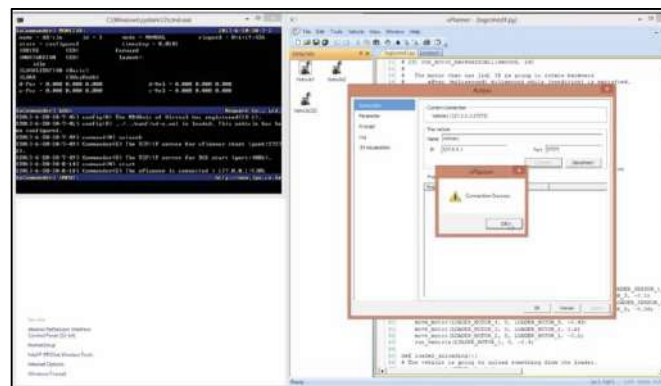
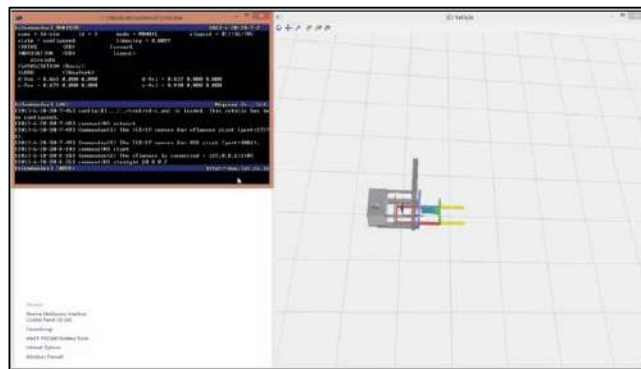

- Purpose**
- vCommander is designed to be installed in vehicles to control them.
 - vCommander receives a moving command from RCS(upper system) and moves vehicles to their destination while identifying moving routes and current positions.
 - vCommander controls various I/O signals and manages all the events involved in vehicle control
 - vCommander operates load and unload devices and interfaces or performs direct control.
- Functions**
- Parameter set : Vehicle speed, Manually operated gear speed, Creep distance, Creep speed settings.
 - Semiautomatic maneuver: Directly produces orders and operates if RCS and online operation are unavailable.
 - Vehicle monitoring : Indicates current location of a vehicle and its running condition.
 - Load and unload learning function: Enables submotors to set proper data on distance to move in advance.
- Features**
- A flexible control system that can be used for various types of automatic guided vehicles.
 - Enables direct correction of load and unload logics by applying scripts (including some running logic)
 - Provides 3D motion simulation functions.
 - Provides SD, QUAD and DD types of wheels and sets a position to attach.
 - Automatically gains access to the route.

Logistics Robot

- Integrated Operating Software of Robots(RCS)

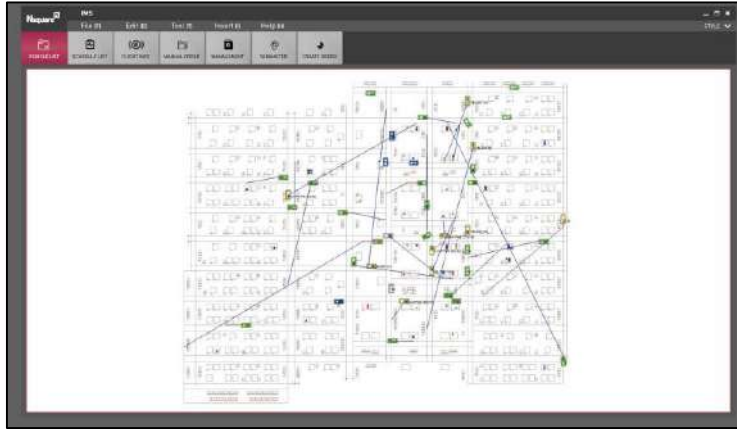

Purpose

- Manages all AGVs within a group of unit, receives and produces orders from hosts or other devices.
- Selects a vehicle suitable for a certain operation and sends operational instructions.
- Operates optimum routes and blocking information after sending orders in real time, and controls and monitors a vehicle until the order is completed in real time.

Functions

- Vehicle status check : Retrieves the status of AGV work, error, and equipment.
- History check : Retrieves work history and error history.
- Order management : Monitors and adjusts the ongoing order status.
- Setting : AGV quantity management and various parameter management

Features

- A system that operates a number of automatic guided vehicles within a given space effectively through the shortest routes without any bumping.
- Job allocation, shortest route check, bumping prediction and avoidance, automatic guided vehicle monitoring.
- Various tuning (workgroup, route adjustment, etc.)

Logistics Robot

- Layout Builder

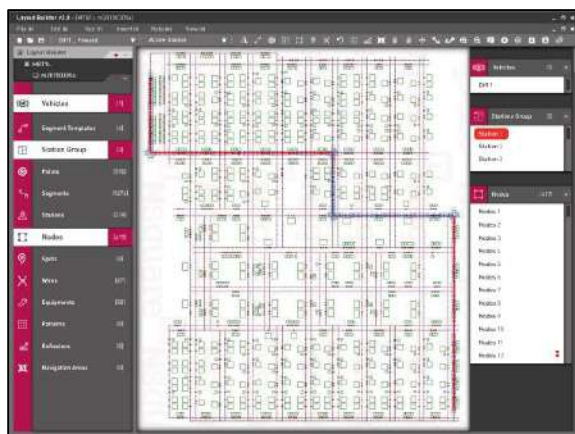

- Purpose**
- A tool to build moving routes of AGV.
 - Data acquired after building will apply to RCS and MCP and a vehicle will identify the actual position and move to its destination.
 - Blocking information can be checked while building a layout and the properties (running style, speed, distance, etc.) can be set.

- Functions**
- Layout building : AGV directly draws the route to move using tools.
 - Properties of entities : Defines properties such as distance, speed, running styles, blocking, angle of entry and exit, etc.
 - Zoom in / out : Zoom in / out layouts.
 - EXPORT : Applies information on routes to MCP.

- Features**
- Running routes of an automatic guided vehicle can be built based on an actual building plan (CAD file).
 - And the blocking area which can be met while is automatically calculated.
 - The files prepared at this point applies to a vehicle control system and a remote control system.
 - If layout changes of the site, it can be applied rapidly.

Logistics Robot

- Simulation Program

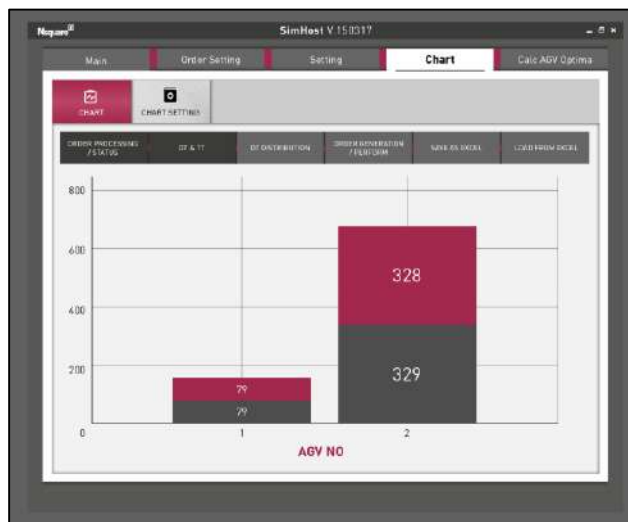

| TIME | INDEX ID | SOURCE | DESTINATION |
|----------|--------------|--------|-------------|
| 00:00:15 | TR1140320001 | CH11_1 | B01_1 |
| 00:01:10 | TR1140320002 | CH02_2 | B01_2 |
| 00:02:05 | TR1140320003 | CH13_1 | B01_1 |
| 00:03:00 | TR1140320004 | CH04_2 | B01_2 |
| 00:03:55 | TR1140320005 | CH09_2 | B01_2 |
| 00:04:50 | TR1140320006 | CH13_2 | B01_2 |
| 00:05:45 | TR1140320007 | CH01_2 | B01_2 |
| 00:06:40 | TR1140320008 | CH02_1 | B01_1 |
| 00:07:35 | TR1140320009 | CH02_2 | B01_2 |
| 00:08:30 | TR1140320010 | CH05_1 | B01_1 |
| 00:09:25 | TR1140320011 | CH11_1 | B01_1 |
| 00:10:20 | TR1140320012 | CH04_2 | B01_2 |
| 00:11:15 | TR1140320013 | CH02_1 | B01_1 |
| 00:12:10 | TR1140320014 | CH01_2 | B01_2 |
| 00:13:05 | TR1140320015 | CH07_2 | B01_2 |
| 00:14:00 | TR1140320016 | CH07_1 | B01_1 |
| 00:14:55 | TR1140320017 | CH13_2 | B01_2 |

- Functions**
- Sets the AGV quantity to be applied.
 - Sets SIM-HOST to produce orders.

- Features**
- A program for simulation to verify if required cargo volume can be processed.
 - Consists of SIM-AGV, RCS and SIM-HOST. The quantity of an automatic guided vehicle can be set.
 - Enables settings of occurrence cycle and frequency of working orders.
 - Provides various analyses information in form of tables and graphs.

Logistics Robot

- Strong Point

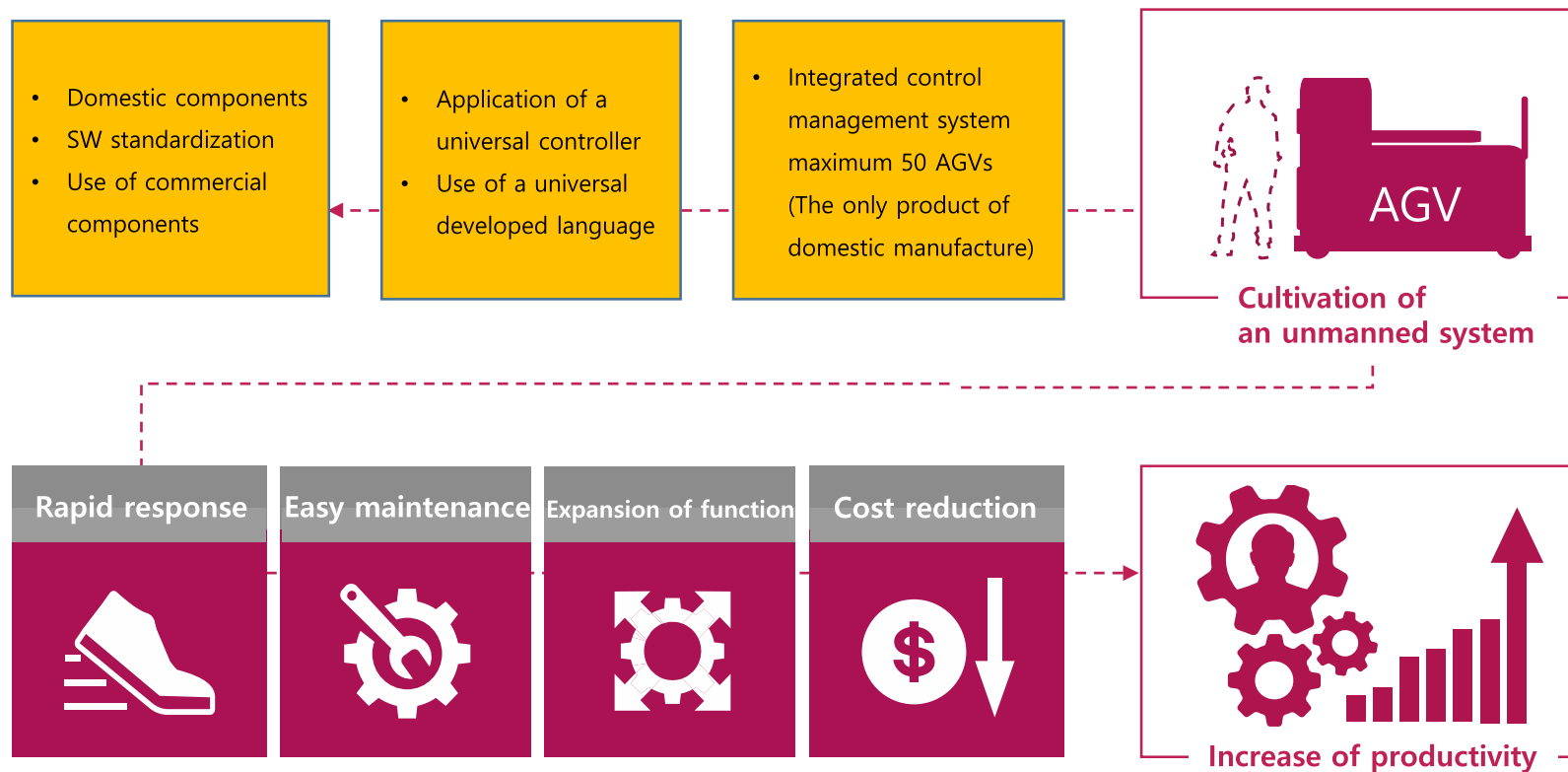

LiDAR sensor

- Light Detecting And Ranging



| | | | | |
|--|--|---|---|--|
| N2 LiDAR | 905 nm, LD <small>Source</small> | Class 1 <small>Laser grade (Eye safety)</small> | 180° <small>Field of View (FOV)</small> | 25 Hz <small>Scanning freq.</small> |
| 0.3° <small>Angle res.</small> | ≥30 m <small>Range</small> | -30°C ~ 60°C <small>Ambient temperature</small> | IP5X <small>Dust protection</small> | 5 to 50Hz (2G) <small>Vibration Test</small> |

03

**Business
Result**

A decorative horizontal bar spanning the width of the page. It features a dark red background with a white grid pattern on the left side, transitioning into a white-to-red gradient on the right side.

Sales Record

1. Samsung Electronics Onyang branch
MBT CFI AGV remodeling (2011)



2. Samsung Electronics Soochow China branch (SESS)
Small size AGV (2011)



Sales Record

3. Samsung Electronics Soochow China branch(SESS)
Medium size AGV (2012)



4. Samsung Electronics Onyang branch
AGV remodeling (2012)



Sales Record

5. Samsung Electronics Gwangju branch
Mold Transfer LGV (2013)



6. Samsung Electronics Gumi branch
Mold Transfer LGV (2013)



Sales Record

7. Samsung Electronics Giheung branch
8Line Pathway AGV (2015)



8. Samsung Electronics Giheung branch
6,8Line Interval Bridge AGV (2014)



Sales Record

9. LGDisplay Paju branch, Guangzhou China branch
Mask AGV (2015)



10. SK Hynix Icheon branch
TDBI AGV (2015)



Sales Record

11. LGDisplay Paju branch, Guangzhou China branch
Unmanned Forklift (2016)



12. CJ KoreaExpress Gunpo branch
Complex logistics center (2018)



Sales Record

13. ILJIN global
Part inspection AGV (2018)



14. LGDisplay Paju branch
Cassette AGV (2018)



Sales Record

15.Schaeffler korea ChangWon branch Multi function robot, AMR (2018)



04

Research and
Development

Research and Development

1. High reach unmanned forklift development.



Research period : 2011. 12 ~ 2014. 07

Government department : Ministry of Land, Transport and Maritime Affairs

2. Warehouse facility automation technology of the logistics site workers standard.



Research period : 2014. 06 ~ 2018. 03

Government department : Ministry of Land, Infrastructure, and Transport

Research and Development

3. Low-cost 2D LiDAR technology for accident prevention and obstacle avoidance of autonomous vehicle.



Research period : 2014. 10 ~ 2016. 09

Government department : Small and Medium Business Administration

4. 5G-based production / logistics service and Cloud-oriented manufacture ML platform development.



Research period : 2018. 04 ~ 2020. 12

Government department : Ministry of Science and ICT

Research and Development

5. 30m-class lidar sensor development for smart factory autonomous transfer robots.



Research period : 2018. 06 ~ 2019. 05

Government department : Ministry of Trade, Industry and Energy

6. in/outdoor omni-directional traveling vehicle development using position recognition technology based on multi-IMU, LiDAR and Camera sensor fusion.



Research period : 2018. 06 ~ 2021. 06

Government department : Ministry of Trade, Industry and Energy

Nsquare

