

The most proactive way to prevent Bird strikes ---

Bird Control Unit



Bird rex 

www.birdrex.com Mobile :010-2760-1442 / e-mail : birdrexKorea@naver.com / birdrexbest@naver.com

History



SEOUL ADEX SHOW October 2019



SEOUL ADEX SHOW October 2021



KAI KOREA AEROSPACE
INDUSTRIES, LTD.

October 2024

We supplied one unit in this year. KAI is operating now.

▪ Size

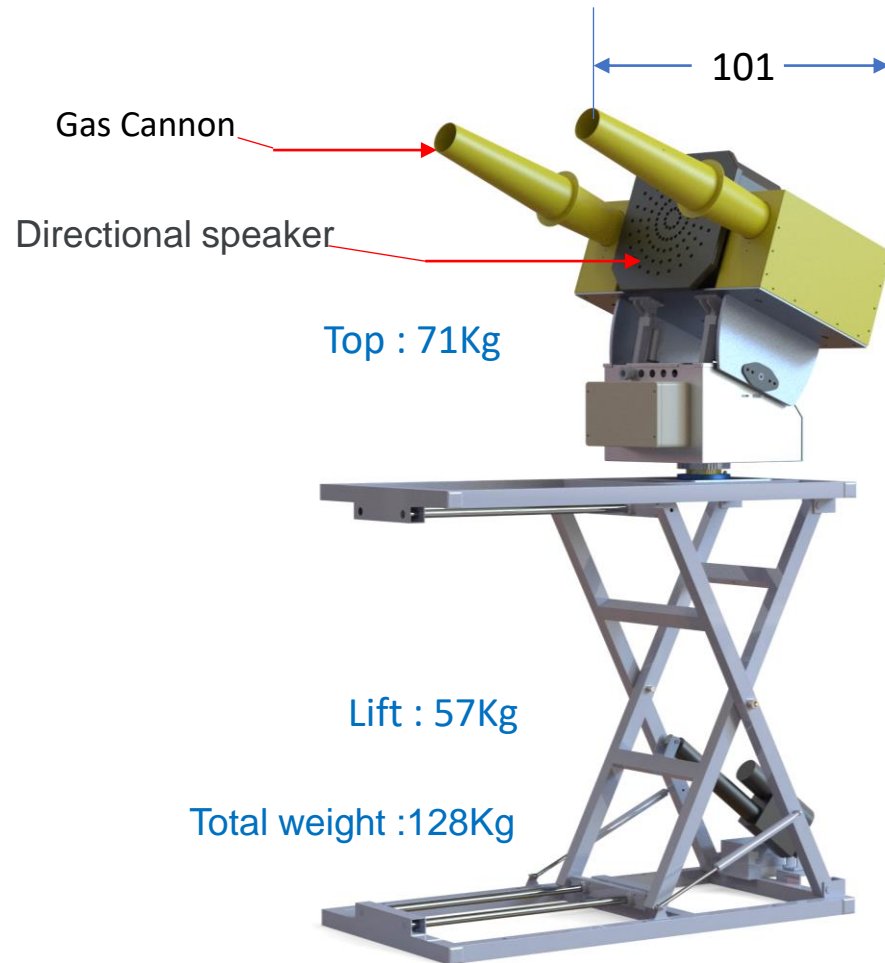
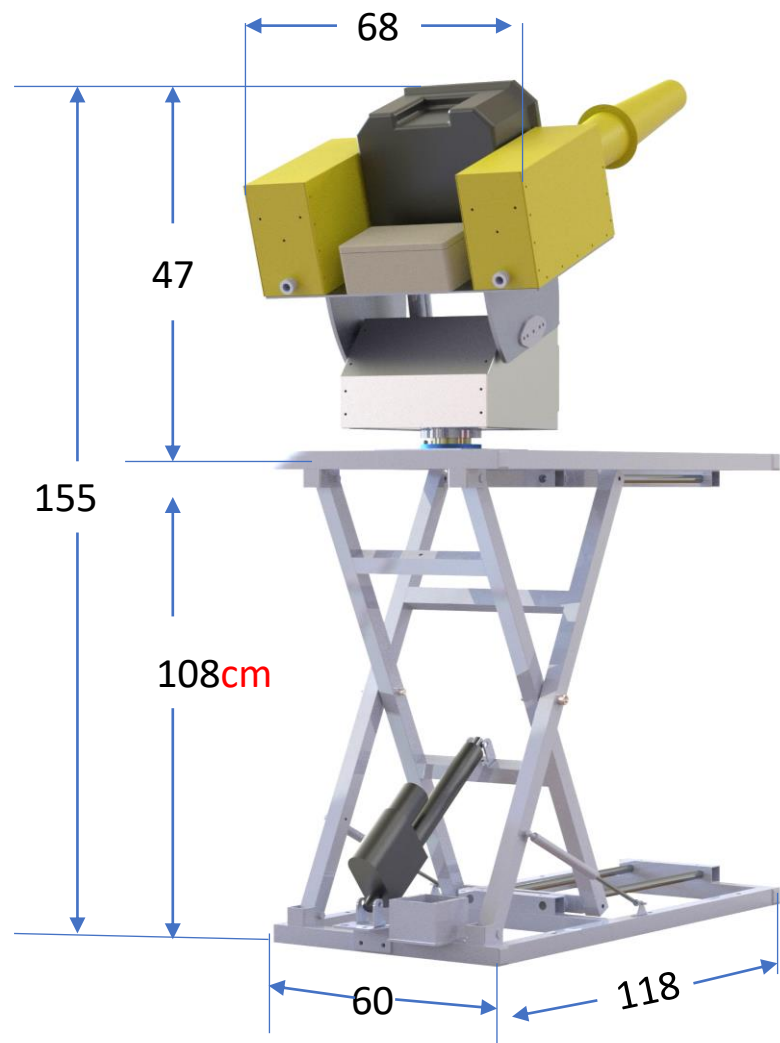

- Lift Speed : UP -14sec. Down-12sec.
- 360° rotation speed : 11sec.
- Upward angle : 60° Max

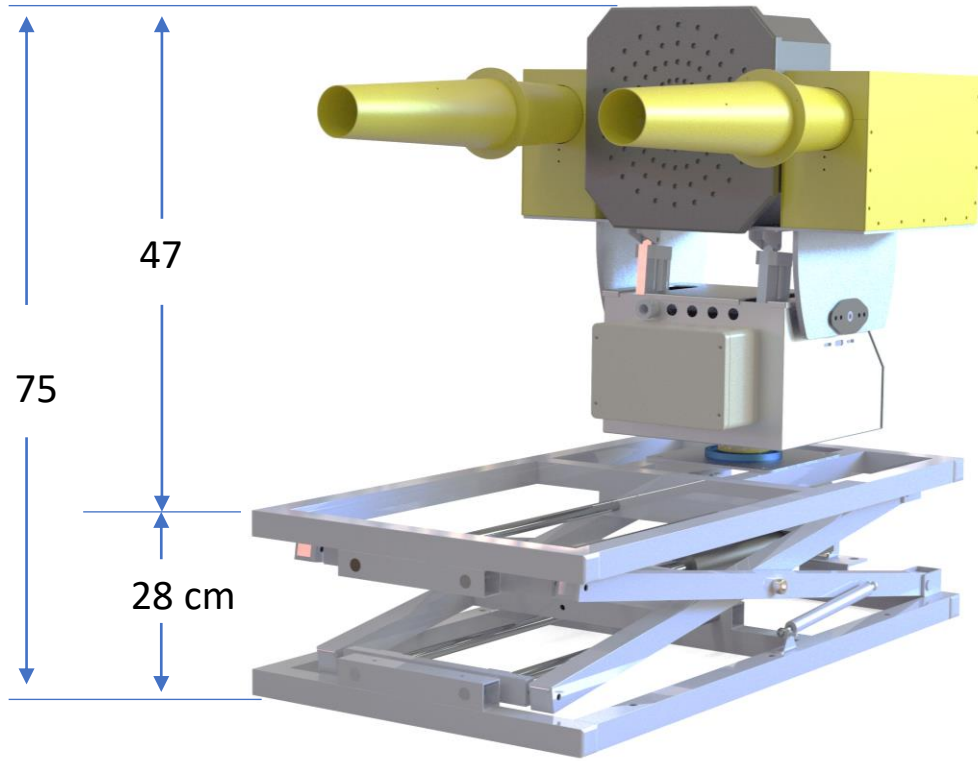

▫ when the Equipment folded

▫ Frequency band : ISM 2.4GHz



▫ Remote Control / 0.9Kg

Remote Control

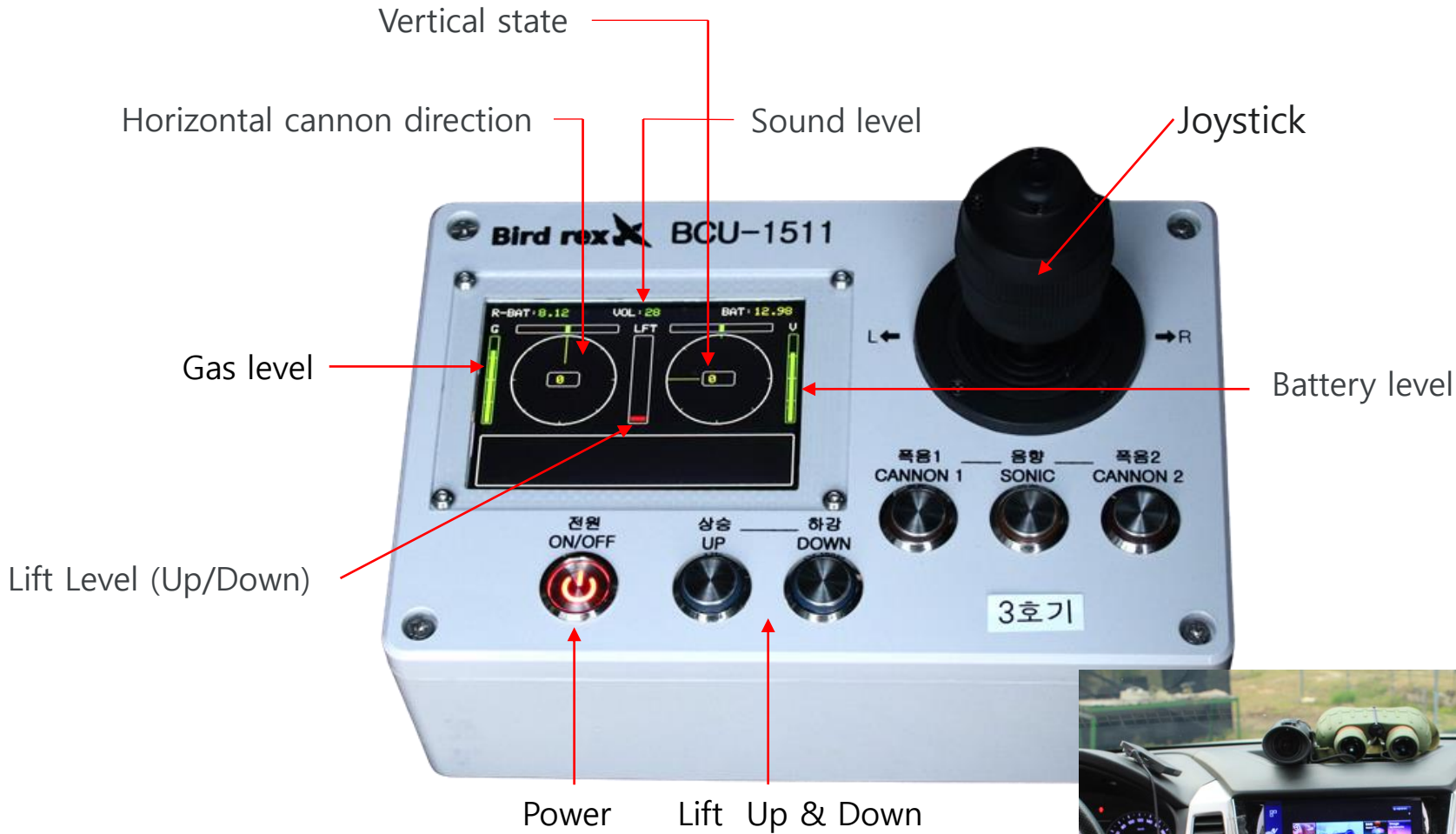

Bird Control Unit – BCU1511

- To the person in charge of bird control operating on Airside
Provide more efficient equipment to ensure aviation safety.
- It is used in Korea's International Airport.
- It started in 2019 and is offering the latest version in 2024.
- Dual Gas Canon and directional acoustic speakers enable immediate and continuous bird repellency.
- One driver works wirelessly easily.
- The lift moves up and down.
The attack equipment rotates 360° and operates up to 60°.

◇ *Bird Rex wants to upgrade and supply equipment suitable for Indian Airport conditions.*